

Spin Physics Experiments @ NICA-SPD with polarized proton and deuteron beams.

Letter of Intent.

**I.Savin, on behalf of the Drafting Committee*), talk at
Workshop NICA-SPIN-2014, Prague, February 10-16.**

CONTENT

- 1. Introduction**
- 2. Physics motivations**
- 3. Requirements to the NUCLOTRON-NICA complex**
- 4. Polarized beams at NICA**
- 5. Requirements to the spin physics detector (SPD)**
- 6. Proposed measurements with SPD**
- 7. Time lines of experiments**

*) I.Savin, A.Efremov, D. Peshekhonov, A. Kovalenko, O.Teryaev, O.Shevchenko,
A. Nagajcev, A. Guskov

Draft



Nec sine te, nec tecum vivere possum. (Ovid)*

Spin Physics Experiments at NICA-SPD with polarized proton and deuteron beams.

(Updating list of participants)

F. Ahmadov¹, R.R. Akhunzyanov¹, V. A. Anosov¹, N.V. Anfimov¹, S. Anishchanka¹²,
X. Artru¹⁵, A.A.Baldin¹, V.G. Baryshevsky¹², A. S. Belov⁵, D. A. Bliznyuk¹⁴, M.Bodlak⁸,
A.V. Butenko¹, A. P. Cheplakov¹, I. E. Chirikov-Zorin¹, G. Domanski¹⁰, S.V. Donskov⁶,
M. Dziewiecki¹⁰, A.V. Efremov¹, Yu. N. Filatov^{1,3}, V.V. Fimushkin¹, M. Finger (jun.)^{7,1},
M. Finger^{7,1}, S.G. Gerassimov¹³, I.A. Golutvin¹, B.V. Grinyov¹⁴, A. Gurinovich¹², A.V. Guskov¹,
Yu. I. Ivanshin¹, A.V. Ivanov¹, V. Jary⁸, A. Janata^{7,1}, N. Javadov¹, L. L. Jenkovszky⁴,
V. D. Kekelidze¹, A.P. Kobushkin⁴, B. Konarzewski¹⁰, A. M. Kondratenko²,
M. A. Kondratenko², I. Konorov¹³, A. D. Kovalenko¹, O. M. Kouznetsov¹, G. A. Kozlov¹,
Z.V. Krumshstein¹, V.V. Kukhtin¹, K. Kurek⁹, P. K. Kurilkin¹, R. Kurjata¹⁰, L.V. Kutuzova¹,
V. P. Ladygin¹, R. Lednický¹, A. Lobko¹², A.I. Malakhov, J. Marzec¹⁰, J. Matousek⁷,
G.V. Meshcheryakov¹, V. A. Mikhaylov¹, Yu.V. Mikhaylov⁶, P.V.Moissenz¹, V.V. Myalkovskiy¹,
A. P. Nagaytsev¹, J. Nový⁸, I.A.Orlov¹, M. Pesek⁷, D.V. Peshekhonov¹, V. D. Peshekhonov¹,
V. A. Polyakov⁶, Yu.V. Prokofichev¹, V. K. Rodionov¹, N. S. Rossiyskaya¹, A. Rouba¹², A. Rychter¹⁰,
V. D. Samoylenko⁶, A.Sandacz⁹, I. A. Savin¹, O.Yu. Shevchenko¹, S.S. Shimanskiy¹,
M. Slunechka^{7,1}, V. Slunechkova^{7,1}, J. Soffer¹¹, G.I.Smirnov¹, N. B. Skachkov¹,
E. A.Strokovsky¹, O.V.Teryaev¹, M. Tomasek⁸, N.D.Topilin¹, A.V.Turbabin⁵, M.Virius⁸, V.Vrba⁸,
M.V. Zavertyaev¹³, K. Zaremba¹⁰, E.V. Zemlyanichkina¹, P.N. Zhmurin¹⁴, M. Ziembicki¹⁰,
V. N. Zubets⁵, I.P. Yudin¹

95 Participants represent 15 Institutions:

- ¹⁵CNRS, Lion, France
- ¹⁴Institute for Scintillation Materials, NAS, Kharkov, Ukraine
- ¹³Lebedev Physics Institute, Moscow, Russia
- ¹²Research Institute for Nuclear Problems, Minsk, Belarus
- ¹¹Temple University, Philadelphia, USA
- ¹⁰Warsaw University of Technology, Institute of Radio electronics, Warsaw, Poland
- ⁹National Center for Nuclear Research, Warsaw, Poland
- ⁸Technical University, Faculty of Nuclear Science and Physics Engineering, Prague, Czech Rep.
- ⁷Charles University, Faculty of Mathematics and Physics, Prague, Czech Republic
- ⁶Institute for High Energy Physics, Protvino, Russia
- ⁵Institute for Nuclear Research of Russian Academy of Sciences, Moscow, Russia
- ⁴Bogolyubov Institute for Theoretical Physics, Kiev, Ukraine
- ³Moscow Institute of Physics and Technology, Dolgoprudny, Russia
- ²Science and Technique Laboratory Zaryad, Novosibirsk, Russia
- ¹Joint Institute for Nuclear Research, Dubna, Russia

Expressed an Interest:

Gomel States University
Moscow States University
St. Petersburg (Gatchina)
ITEPH, Moscow
Italy
USA (A.Krish +2 students)

1. Introduction.









1.1. Basic PDFs of nucleons.

1.2. DIS as a microscope for nucleons. The PDF f_1 and g_1 .

1.3. New TMD PDFs.

1.4. Other actual problems of high energy physics.

INTRODUCTION. 1.1. Basic twist-2 PDFs of the nucleons
(vertical – nucleon, horizontal – quark polarization)

| $N \backslash q$ | U | L | T | |
|------------------|--------------------------------------------------------------------------------------------------------------|---------------------------------------------------------------------------------------------------------------------|-------------------------------------------------------------------------------------------------------------------------------------------------------------------------------------------------------------------------------------|------------|
| U | f_1  Number Density | | h_1^\perp  Boer-Mulders | T-odd |
| L | | g_1  Helicity | h_{1L}^\perp  Worm-gear - L | |
| T | f_{1T}^\perp  Sivers | g_{1T}^\perp  Worm-gear - T | h_1  Transversity h_{1T}^\perp  Pretzelosity | chiral-odd |

| | U | L | T |
|---|----------------------------|-------------------------------|------------------------------------------------|
| U | f_1 Number Density | | h_1^\perp Boer-Mulders |
| L | | g_1 Helicity | h_{1L}^\perp Worm-gear-L |
| T | f_{1T}^\perp Sivers | g_{1T}^\perp Worm-gear-T | h_{1T}^\perp Transversity Pretzelosity |

Twist-2 PDFs of nucleons :

- f_1 - **density** of partons in non-polarized nucleon, (x, Q^2) ;
- g_1 - **helicity**, longitudinal polarization of quarks in longitudinally polarized nucleon;
- h_1 - **transversity**, transverse polarization of quarks in transversely polarized nucleon ;
- f_{1T}^\perp - **Sivers**, correlation between the transverse polarization of nucleon (transverse spin) and the transverse momentum of non-polarized quarks ;
- g_{1T}^\perp - **worm-gear-T**, correlation between the transverse spin and the longitudinal quark polarization ;
- h_{1L}^\perp - **Boer-Mulders**, distribution of the quark transverse momentum in the non-polarized nucleon ;
- h_{1T}^\perp - **worm-gear-L**, correlation between the longitudinal polarization of the nucleon (longitudinal spin) and the transverse momentum of quarks ;
- h_{1T}^\perp - **pretzelosity**, distribution of the transverse momentum of quarks in the transversely polarized nucleon ;

Introduction. 1.2. PDFs f_1 and g_1

f_1 . Measured from Inclusive Deep Inelastic lepton (l)-nucleon (N) Scattering (**IDIS**) : $l + N \rightarrow l' + X$, nucleon can be polarized .

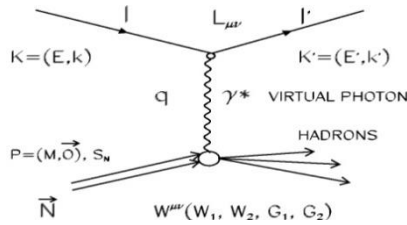

$$\frac{d^2 \vec{\sigma}^{S_e S_N}}{d\Omega dE'} = \frac{d^2 \sigma^{unp}}{d\Omega dE'} + S_N S_e \frac{d^2 \sigma^{pol}}{d\Omega dE'}$$

$$\sigma^{unp} \equiv \frac{d^2 \sigma^{unp}}{dx dQ^2} = \frac{4\pi\alpha^2}{Q^4 x} F_2(x, Q^2) \left[1 - y - \frac{y^2 \gamma^2}{4} + \frac{y^2 (1 + \gamma^2)}{2(1 + R(x, Q^2))} \right]$$

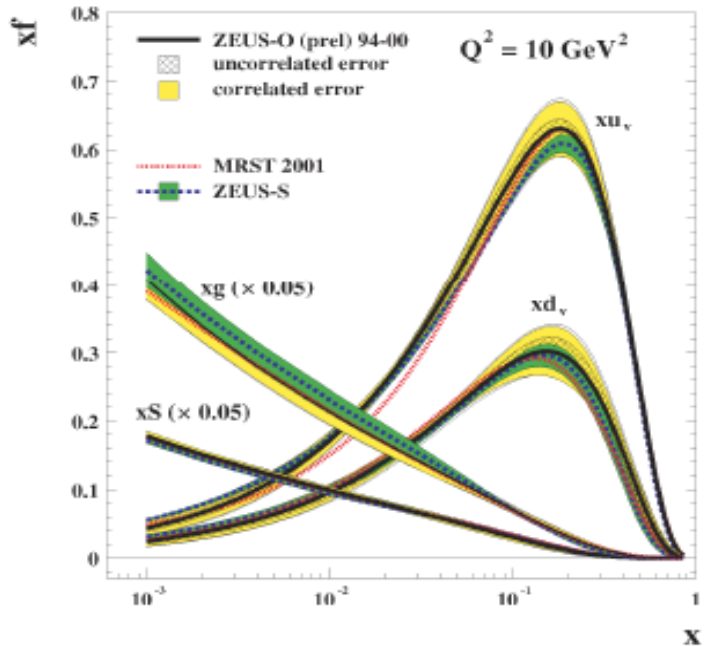

$R(x, Q^2)$ and $F_2(x, Q^2)$ have been measured by the collaborations SLAC, EMC, BCDMS, NMC, ZEUS, H₁ and others.

In QCD:

$$F_2(x, Q^2) = x \sum_q e_q^2 [q(x, Q^2) + anti-q(x, Q^2)], \quad q = u, d, s.$$

PDFs f_1^a ($a \equiv q$) are determined from the QCD analysis of all IDIS data

Introduction.

1.2. PDFs f_1 and g_1

Measured from σ^{pol} separated off σ^{tot} in so-called *asymmetries*.

g_1

The cross sections difference, $\Delta\sigma_{//}$, for two opposite longitudinal target polarizations is given by the expression:

$$\Delta\sigma_{//} \equiv \Delta\left(\frac{d^2\sigma_{//}^{pol}}{dx dQ^2}\right) = \frac{16\pi\alpha^2 y}{Q^4} \left[\left(1 - \frac{y}{2} - \frac{y^2\gamma^2}{4}\right) g_1 - \frac{y\gamma^2}{2} g_2 \right],$$

connected with the longitudinal asymmetry, $A_{//}$, defined as

$$A_{//} = \frac{\Delta\sigma_{//}}{2\sigma^{unp}} = \frac{\sigma^{\rightarrow\rightarrow} - \sigma^{\leftarrow\leftarrow}}{\sigma^{\rightarrow\leftarrow} + \sigma^{\leftarrow\rightarrow}}$$

which, in the first approximation, related to g_1 :

$$A_{//}/D \approx A_1 \approx (g_1 - \gamma^2 g_2)/F_1 \approx g_1/F_1,$$

The QPM expression for virtual photon asymmetry A_1 :

$$A_1^p = \frac{\sigma_{1/2}^p - \sigma_{3/2}^p}{\sigma_{1/2}^p + \sigma_{3/2}^p} = \frac{\sum_i e_i^2 \left[\overline{q_i^\uparrow(x)} - \overline{q_i^\downarrow(x)} \right]}{\sum_i e_i^2 \left[\overline{q_i^\uparrow(x)} + \overline{q_i^\downarrow(x)} \right]} \quad g_1(x) = \sum_i e_i^2 \left[\overline{q_i^\uparrow(x)} - \overline{q_i^\downarrow(x)} \right]$$

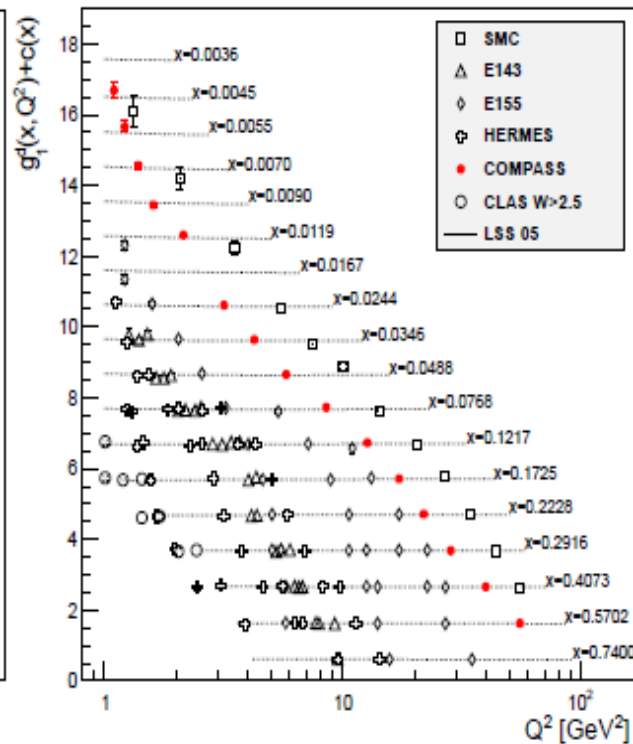
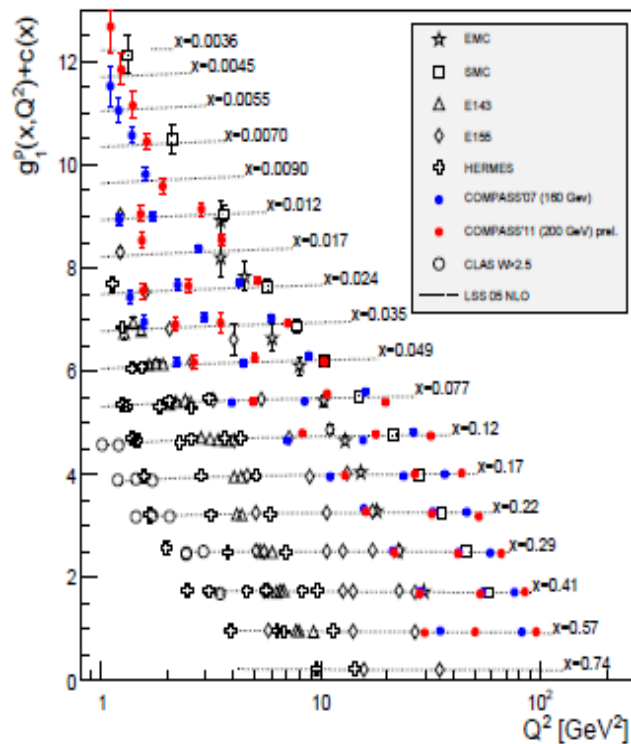

COMPASS, Phys. Lett. B 680 (2009) 217

DSSV, Phys. Rev. D 80 (2009) 034030

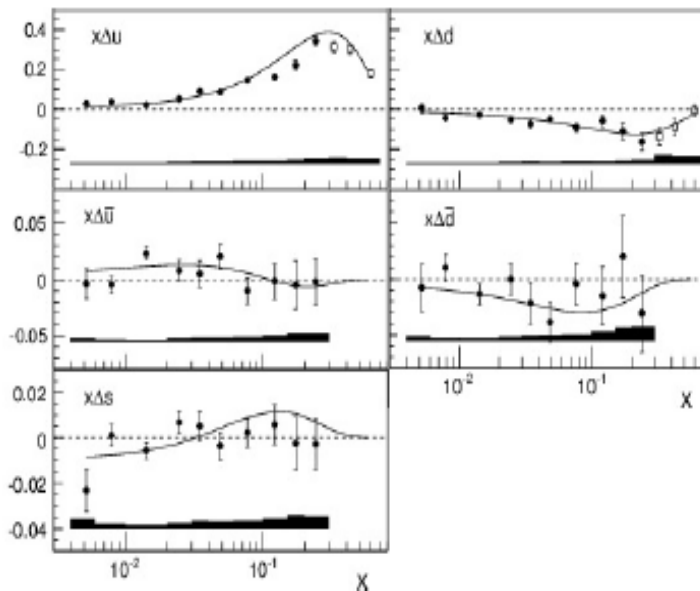
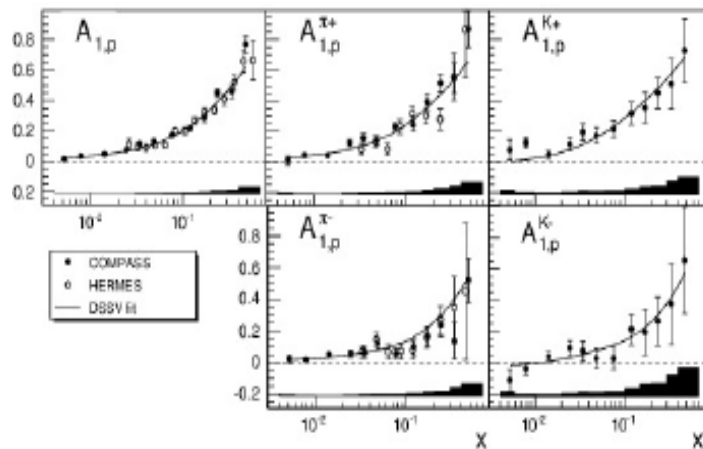

INTRODUCTION.

1.3. TMD PDFs

Transversity PDF h_1

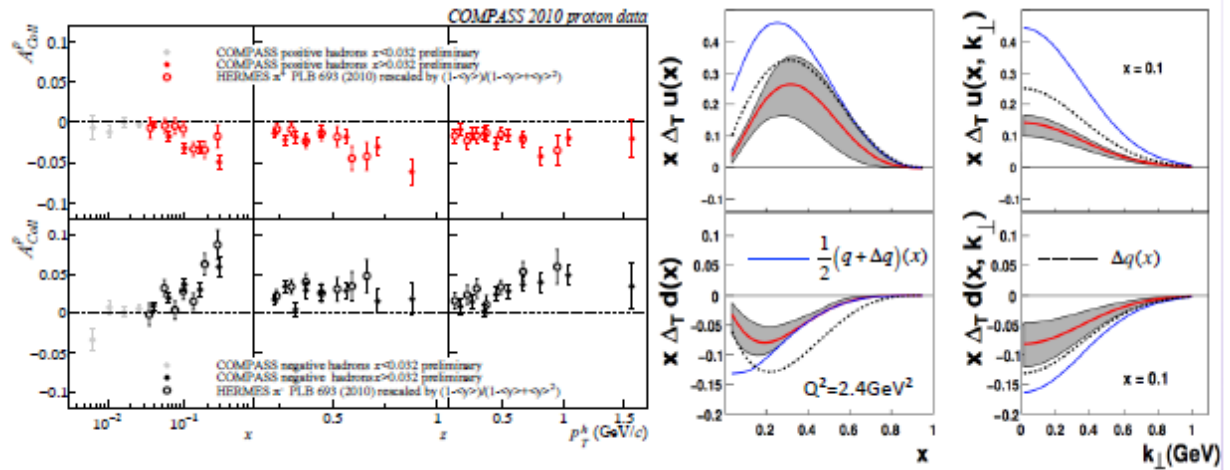

Sivers PDF f_{1T}^\perp

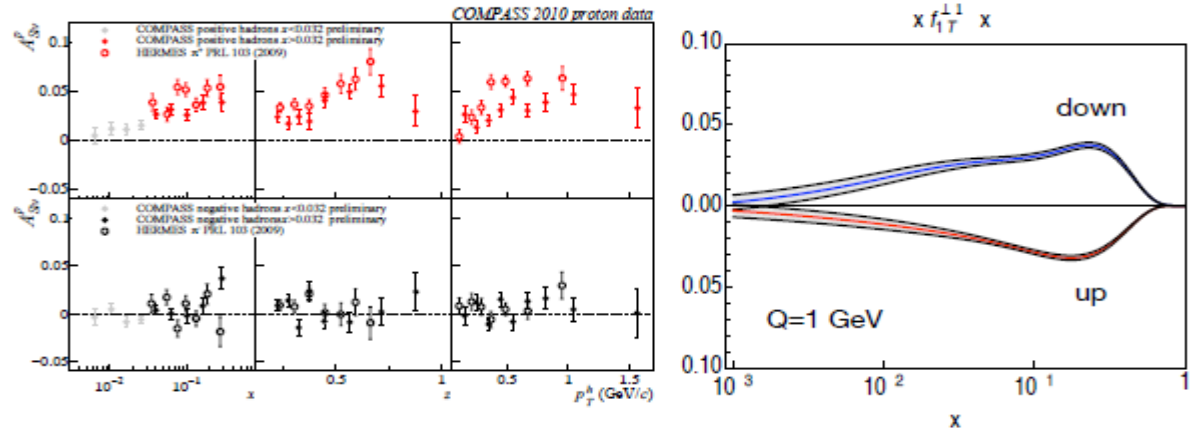

No data : Pretzelosity PDF h_{1T}^\perp Worm-gear-L h_{1L}^\perp Worm-gear-T g_{1T}^\perp Boer-Mulders h_{1T}^\perp

INTRODUCTION. 1.4. Other actual problems of high energy physics

2-SPIN PROTON-PROTON ELASTIC CROSS SECTIONS

12 GeV ZGS
1977-1978

SPINS PARALLEL 4X SPINS ANTIPARALLEL
TOTALLY UNEXPECTED

Questions by Profs. Weisskopf & Bethe:
High P_{\perp} or 90°_{cm} , Identical Particles?

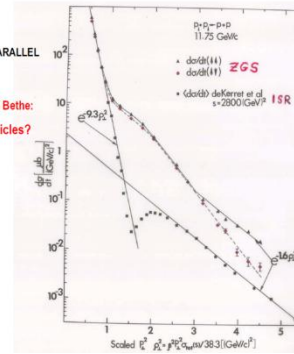

Answer to Questions by Profs. Weisskopf & Bethe

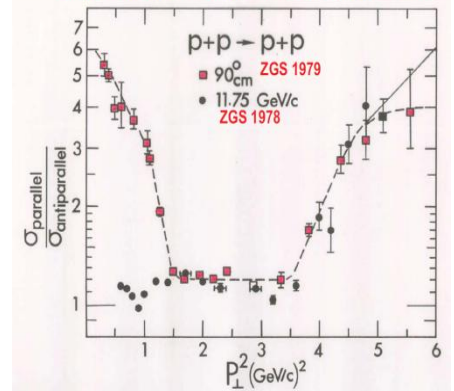

AGS 1985-1990 A_n
PERTURBATIVE QCD \Rightarrow
 $A_n = 0$ at HIGH P_{\perp}^2 and HIGH ENERGY

$A_n \neq 0 \Rightarrow$
PROBLEM with PQCD?

NO MODEL can EXPLAIN ALL
HIGH- P_{\perp}^2 SPIN EFFECTS (A_n & A_{nn})

GOAL
MEASURE A_n (and A_{nn})
up to $P_{\perp}^2 = 12$ (GeV/c)

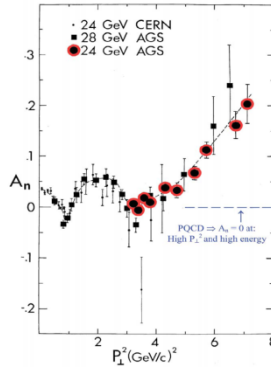

INCLUSIVE HYPERON POLARIZATION

Devlin, Pondrum, Bunce, Heller *et al.* 1976-80

Fermilab 400 GeV p+p \rightarrow Lambda

Plot by Heller ~1980
with KEK & ISR data

$P \sim 15-20\%$
QCD says $P \sim 0$

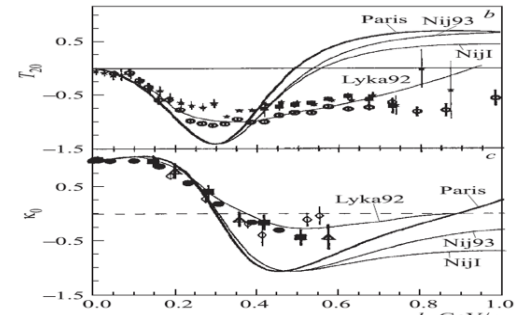
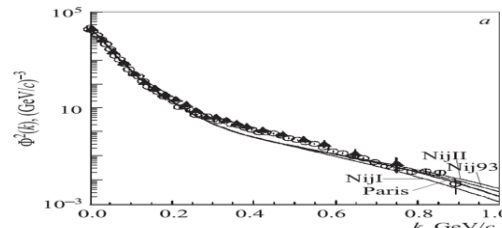
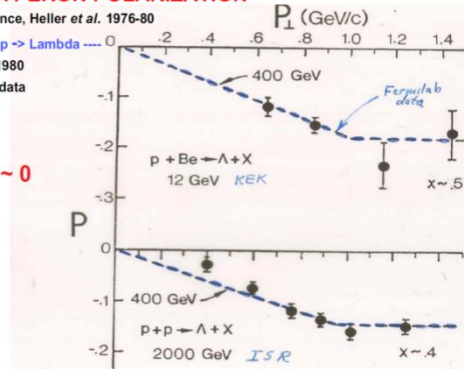

2. Physics motivations

2.1. Nucleon spin structure studies using the Drell-Yan mechanism. (AE)

2.2. New nucleon PDFs and J/Ψ production mechanisms. (OSh)

2.3. Direct photons. (AG)

2.4. Spin-dependent high- p_T reactions. (SSh)

2.5. Spin-dependent effects in elastic pp and dd scattering. (OT)

2.6. Spin-dependent reactions in heavy ion collisions. (OT)

2.7. Future experiments on nucleon structure in the world. (AN)

Physics motivations.

2.1. Nucleon structure studies using the Drell-Yan mechanism.

$$H_a(P_a, S_a) + H_b(P_b, S_b) \rightarrow l^-(l, \lambda) + l^+(l', \lambda') + X,$$

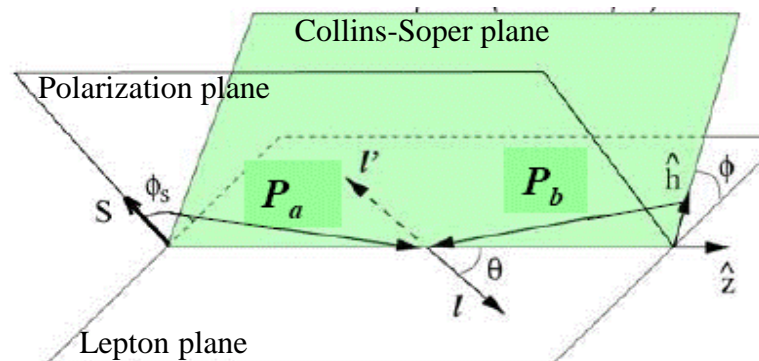
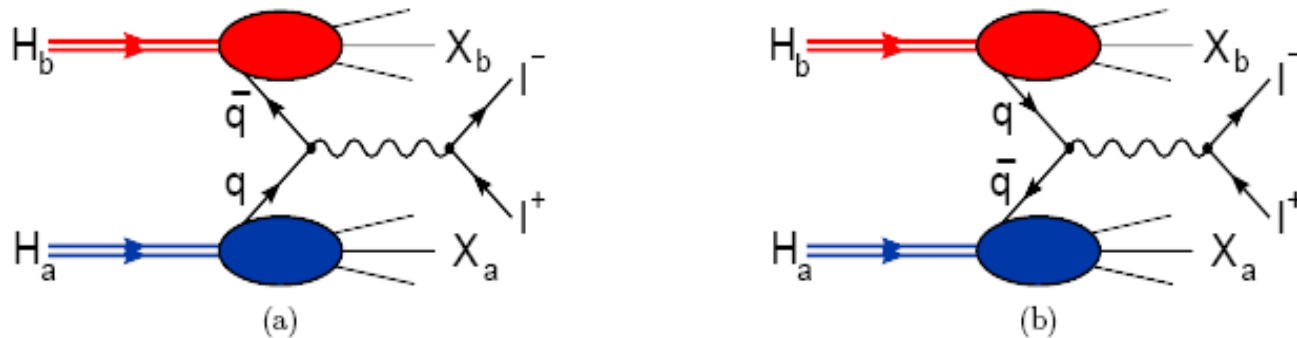

$$\begin{aligned}
\frac{d\sigma}{dx_a dx_b d^2q_T d\Omega} &= \frac{\alpha^2}{4Q^2} \times \\
&\left\{ (1 + \cos^2 \theta) F_{UU}^1 + \sin^2 \theta \cos 2\phi F_{UU}^{\cos 2\phi} + S_{aL} \sin^2 \theta \sin 2\phi F_{LU}^{\sin 2\phi} + S_{bL} \sin^2 \theta \sin 2\phi F_{UL}^{\sin 2\phi} \right. \\
&+ \left| \vec{S}_{aT} \right| \left[\sin(\phi - \phi_{S_a}) (1 + \cos^2 \theta) F_{TU}^{\sin(\phi - \phi_{S_a})} + \sin^2 \theta \sin(3\phi - \phi_{S_a}) F_{TU}^{\sin(3\phi - \phi_{S_a})} + \sin(\phi + \phi_{S_a}) F_{TU}^{\sin(\phi + \phi_{S_a})} \right] \\
&+ \left| \vec{S}_{bT} \right| \left[\sin(\phi - \phi_{S_b}) (1 + \cos^2 \theta) F_{UT}^{\sin(\phi - \phi_{S_b})} + \sin^2 \theta \sin(3\phi - \phi_{S_b}) F_{UT}^{\sin(3\phi - \phi_{S_b})} + \sin(\phi + \phi_{S_b}) F_{UT}^{\sin(\phi + \phi_{S_b})} \right] \\
&+ S_{aL} S_{bL} \left[(1 + \cos^2 \theta) F_{LL}^1 + \sin^2 \theta \cos 2\phi F_{LL}^{\cos 2\phi} \right] \\
&+ S_{aL} \left| \vec{S}_{bT} \right| \left[\cos(\phi - \phi_{S_b}) (1 + \cos^2 \theta) F_{LT}^{\cos(\phi - \phi_{S_b})} + \sin^2 \theta \cos(3\phi - \phi_{S_b}) F_{LT}^{\cos(3\phi - \phi_{S_b})} + \cos(\phi + \phi_{S_b}) F_{LT}^{\cos(\phi + \phi_{S_b})} \right] \\
&+ \left| \vec{S}_{aT} \right| S_{bL} \left[\cos(\phi - \phi_{S_a}) (1 + \cos^2 \theta) F_{TL}^{\cos(\phi - \phi_{S_a})} + \sin^2 \theta \cos(3\phi - \phi_{S_a}) F_{TL}^{\cos(3\phi - \phi_{S_a})} + \cos(\phi + \phi_{S_a}) F_{TL}^{\cos(\phi + \phi_{S_a})} \right] \\
&+ \left| \vec{S}_{aT} \right| \left| \vec{S}_{bT} \right| \left[(1 + \cos^2 \theta) \cos(2\phi - \phi_{S_a} - \phi_{S_b}) F_{TT}^{\cos(2\phi - \phi_{S_a} - \phi_{S_b})} + \cos(\phi_{S_b} - \phi_{S_a}) F_{TT}^{\cos(\phi_{S_b} - \phi_{S_a})} \right] \\
&+ \left| \vec{S}_{aT} \right| \left| \vec{S}_{bT} \right| \left[\sin^2 \theta \cos(\phi_{S_a} + \phi_{S_b}) F_{TT}^{\cos(\phi_{S_a} + \phi_{S_b})} + \cos(4\phi - \phi_{S_a} - \phi_{S_b}) F_{TT}^{\cos(4\phi - \phi_{S_a} - \phi_{S_b})} \right] \\
&+ \left. \left| \vec{S}_{aT} \right| \left| \vec{S}_{bT} \right| \left[\sin^2 \theta \cos(2\phi - \phi_{S_a} + \phi_{S_b}) F_{TT}^{\cos(2\phi - \phi_{S_a} + \phi_{S_b})} + \cos(2\phi + \phi_{S_a} - \phi_{S_b}) F_{TT}^{\cos(2\phi + \phi_{S_a} - \phi_{S_b})} \right] \right\} \quad (2.1.2)
\end{aligned}$$

F_j^i are the SFs, depend on four variables $P_a \cdot q$, $P_b \cdot q$, \mathbf{q}_T and q^2 or on \mathbf{q}_T , q^2 and the Bjorken variables of colliding hadrons, x_a , x_b ,

$$x_a = \frac{q^2}{2P_a \cdot q} = \sqrt{\frac{q^2}{s}} e^y, \quad x_b = \frac{q^2}{2P_b \cdot q} = \sqrt{\frac{q^2}{s}} e^{-y}, \quad \mathbf{q}_T \text{ and } q^2, \quad y \text{ is the } cm \text{ rapidity.}$$

The Eq. (2.1.2) includes 24 leading twist SFs. Each of them is expressed through a weighted convolution, C , of corresponding leading twist TMD PDF in the transverse momentum space,

$$C\left[w(\vec{k}_{aT}, \vec{k}_{bT}) f_1 \bar{f}_2\right] \equiv \frac{1}{N_c} \sum_q e_q^2 \int d^2\vec{k}_{aT} d^2\vec{k}_{bT} \delta^2(\vec{q}_T - \vec{k}_{aT} - \vec{k}_{bT}) w(\vec{k}_{aT}, \vec{k}_{bT}) \times \\ \left[f_{1q}(x_a, \vec{k}_{aT}^2) \bar{f}_{2q}(x_b, \vec{k}_{bT}^2) + \bar{f}_{1q}(x_a, \vec{k}_{aT}^2) f_{2q}(x_b, \vec{k}_{bT}^2) \right],$$

where k_{aT} (k_{bT}) is the transverse momentum of quark in the hadron H_a (H_b) and f_1 (f_2) is a TMD PDF of the corresponding hadron.

Expressions for **all leading twist SFs of quarks and antiquarks** entering Eq. (2.1.2) **are given in the text of LoI**. F.e. in **unpolarized** case:

$$F_{UU}^1 = C\left[f_1 \bar{f}_1\right], \quad F_{UU}^{\cos 2\phi} = C\left[\frac{2(\vec{h} \cdot \vec{k}_{aT})(\vec{h} \cdot \vec{k}_{bT}) - \vec{k}_{aT} \cdot \vec{k}_{bT}}{M_a M_b} h_1^\perp \bar{h}_1^\perp\right],$$

where **h^\perp** is the Boer-Mulders PDF

8 asymmetries to be measured: $A_{LU}, A_{UL}, A_{TU}, A_{UT}, A_{LL}, A_{TL}, A_{LT}, A_{TT}$

$$A_{UU} \equiv \frac{\sigma_{int}^{00}}{\sigma_{int}^{00}} = \frac{1}{2\pi} (1 + D \cos 2\phi A_{UU}^{\cos 2\phi})$$

$$A_{LU} \equiv \frac{\sigma_{int}^{\rightarrow 0} - \sigma_{int}^{\leftarrow 0}}{\sigma_{int}^{\rightarrow 0} + \sigma_{int}^{\leftarrow 0}} = \frac{|S_{aL}|}{2\pi} D \sin 2\phi A_{LU}^{\sin 2\phi}$$

$$A_{UL} \equiv \frac{\sigma_{int}^{0\rightarrow} - \sigma_{int}^{0\leftarrow}}{\sigma_{int}^{0\rightarrow} + \sigma_{int}^{0\leftarrow}} = \frac{|S_{bL}|}{2\pi} D \sin 2\phi A_{UL}^{\sin 2\phi}$$

$$A_{TU} \equiv \frac{\sigma_{int}^{0\uparrow} - \sigma_{int}^{0\downarrow}}{\sigma_{int}^{0\uparrow} + \sigma_{int}^{0\downarrow}} = \frac{|\vec{S}_{aT}|}{2\pi} \left[A_{TU}^{\sin(\phi - \phi_{S_a})} \sin(\phi - \phi_{S_a}) + D \left(A_{TU}^{\sin(3\phi - \phi_{S_a})} \sin(3\phi - \phi_{S_a}) + A_{TU}^{\sin(\phi + \phi_{S_a})} \sin(\phi + \phi_{S_a}) \right) \right]$$

$$A_{UT} \equiv \frac{\sigma_{int}^{0\uparrow} - \sigma_{int}^{0\downarrow}}{\sigma_{int}^{0\uparrow} + \sigma_{int}^{0\downarrow}} = \frac{|\vec{S}_{bT}|}{2\pi} \left[A_{UT}^{\sin(\phi - \phi_{S_b})} \sin(\phi - \phi_{S_b}) + D \left(A_{UT}^{\sin(3\phi - \phi_{S_b})} \sin(3\phi - \phi_{S_b}) + A_{UT}^{\sin(\phi + \phi_{S_b})} \sin(\phi + \phi_{S_b}) \right) \right]$$

$$A_{LL} \equiv \frac{\sigma_{int}^{\rightarrow\rightarrow} + \sigma_{int}^{\leftarrow\leftarrow} - \sigma_{int}^{\rightarrow\leftarrow} - \sigma_{int}^{\leftarrow\rightarrow}}{\sigma_{int}^{\rightarrow\rightarrow} + \sigma_{int}^{\leftarrow\leftarrow} + \sigma_{int}^{\rightarrow\leftarrow} + \sigma_{int}^{\leftarrow\rightarrow}} = \frac{|S_{aL} S_{bL}|}{2\pi} \left(A_{LL}^1 + D A_{LL}^{\cos 2\phi} \cos 2\phi \right)$$

$$A_{TL} \equiv \frac{\sigma_{int}^{\uparrow\rightarrow} + \sigma_{int}^{\downarrow\leftarrow} - \sigma_{int}^{\downarrow\rightarrow} - \sigma_{int}^{\uparrow\leftarrow}}{\sigma_{int}^{\uparrow\rightarrow} + \sigma_{int}^{\downarrow\leftarrow} + \sigma_{int}^{\downarrow\rightarrow} + \sigma_{int}^{\uparrow\leftarrow}} = \frac{|\vec{S}_{aT}| |S_{bL}|}{2\pi} \left[A_{TL}^{\cos(\phi - \phi_{S_a})} \cos(\phi - \phi_{S_a}) + D \left(A_{TL}^{\cos(3\phi - \phi_{S_a})} \cos(3\phi - \phi_{S_a}) + A_{TL}^{\cos(\phi + \phi_{S_a})} \cos(\phi + \phi_{S_a}) \right) \right]$$

$$A_{LT} \equiv \frac{\sigma_{int}^{\rightarrow\uparrow} + \sigma_{int}^{\leftarrow\downarrow} - \sigma_{int}^{\rightarrow\downarrow} - \sigma_{int}^{\leftarrow\uparrow}}{\sigma_{int}^{\rightarrow\uparrow} + \sigma_{int}^{\leftarrow\downarrow} + \sigma_{int}^{\rightarrow\downarrow} + \sigma_{int}^{\leftarrow\uparrow}} = \frac{S_{aL} |\vec{S}_{bT}|}{2\pi} \left[A_{LT}^{\cos(\phi - \phi_{S_b})} \cos(\phi - \phi_{S_b}) + D \left(A_{LT}^{\cos(3\phi - \phi_{S_b})} \cos(3\phi - \phi_{S_b}) + A_{LT}^{\cos(\phi + \phi_{S_b})} \cos(\phi + \phi_{S_b}) \right) \right]$$

$$A_{TT} \equiv \frac{\sigma_{int}^{\uparrow\uparrow} + \sigma_{int}^{\downarrow\downarrow} - \sigma_{int}^{\uparrow\downarrow} - \sigma_{int}^{\downarrow\uparrow}}{\sigma_{int}^{\uparrow\uparrow} + \sigma_{int}^{\downarrow\downarrow} + \sigma_{int}^{\uparrow\downarrow} + \sigma_{int}^{\downarrow\uparrow}} = \frac{|\vec{S}_{aT}| \|\vec{S}_{bT}\|}{2\pi} \left[A_{TT}^{\cos(2\phi - \phi_{S_a} - \phi_{S_b})} \cos(2\phi - \phi_{S_a} - \phi_{S_b}) + A_{TT}^{\cos(\phi_{S_b} - \phi_{S_a})} \cos(\phi_{S_b} - \phi_{S_a}) \right]$$

$$+ D \left(A_{TT}^{\cos(\phi_{S_b} + \phi_{S_a})} \cos(\phi_{S_a} + \phi_{S_b}) + A_{TT}^{\cos(4\phi - \phi_{S_a} - \phi_{S_b})} \cos(4\phi - \phi_{S_a} - \phi_{S_b}) \right)$$

$$+ A_{TT}^{\cos(2\phi - \phi_{S_a} + \phi_{S_b})} \cos(2\phi - \phi_{S_a} + \phi_{S_b}) + A_{TT}^{\cos(2\phi + \phi_{S_a} - \phi_{S_b})} \cos(2\phi + \phi_{S_a} - \phi_{S_b}) \Big] \quad (2.1.10)$$

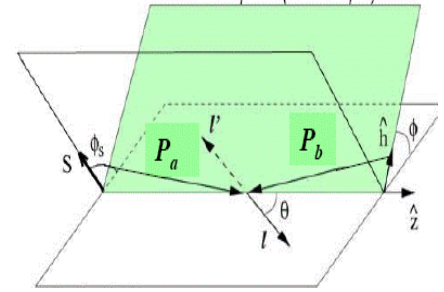

In above expressions: cross section σ^{pq} with superscripts:
horizontal arrows - for positive (negative) longitudinal beam polarizations
vertical arrows - for transversal beam polarization ,
0 - for the non-polarized hadrons .

$$D = \sin^2 \theta / (1 + \cos^2 \theta)$$

$$A_{jk}^i = F_{jk}^i / F_{UU}^1 \quad \text{--amplitude of SF modulation}$$

Applying the Fourier analysis to the measured asymmetries,
one can separate each of all ratios $A_{jk}^i = F_{jk}^i / F_{UU}^1$ entering Eq. 2.1.10.

The large number of independent SFs to be determined from the polarized DY processes at NICA (24 for identical hadrons in the initial state) is sufficient to map out all eight leading twist TMD PDFs for quarks and anti-quarks.

Physics motivations. 2.3. Direct photons.

Direct photon productions in the non-polarized and polarized pp (pd) reactions provide information on the **gluon distributions** in nucleons

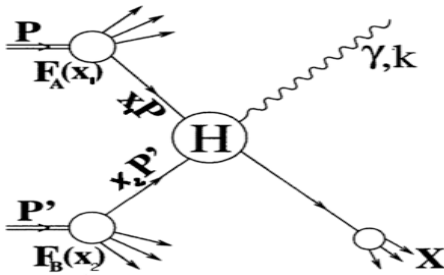

Vertex H corresponds to $q + qbar \rightarrow \gamma + g$ or $g + q \rightarrow \gamma + q$ hard processes.

One can show that the polarized gluon distribution (Sivers gluon function) can be extracted from measurement of the **transverse single spin asymmetry** $A_N = \frac{\sigma^\uparrow - \sigma^\downarrow}{\sigma^\uparrow + \sigma^\downarrow}$ of order few %.

Via double spin asymmetry A_{LL} one can measure a **gluon polarization** in the nucleon:

$$A_{LL} \approx \frac{\Delta g(x_1)}{g(x_1)} \cdot \left[\frac{\sum_q e_q^2 [\Delta q(x_2) + \Delta \bar{q}(x_2)]}{\sum_q e_q^2 [q(x_2) + \bar{q}(x_2)]} \right] \cdot \hat{a}_{LL}(gq \rightarrow \gamma q) + (1 \leftrightarrow 2),$$

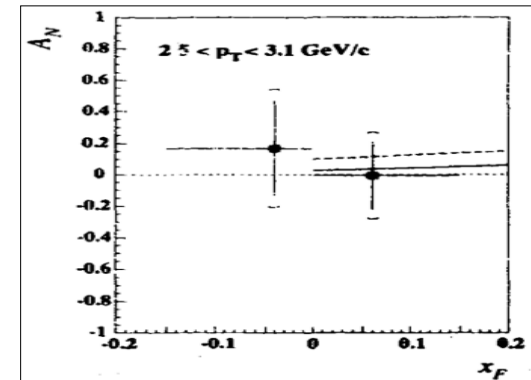

3. Requirements to the NUCLOTRON-NICA complex. (IS)

Beams. The following beams will be needed, polarized and non-polarized:

$$pp, pd, dd, p \uparrow p \uparrow, p \uparrow d \uparrow, p \uparrow d \uparrow, d \uparrow d \uparrow.$$

Beam polarizations both at MPD and SPD: longitudinal and transversal. Absolute values of polarizations should be $\geq 50\%$. The life time of the beam polarization should be long enough, ≥ 24 h. Measurements of Single Spin and Double Spin asymmetries in DY require running in different beam polarization modes: $UU, LU, UL, TU, UT, LL, LT$ and TL (spin flipping for every bunch or group of bunches should be considered).

Beam energies: $p \uparrow p \uparrow (\sqrt{s_{pp}}) = 12 \div \geq 27$ GeV ($5 \div \geq 12.6$ GeV kinetic energy),
 $d \uparrow d \uparrow (\sqrt{s_{NN}}) = 4 \div \geq 13.8$ GeV ($2 \div \geq 5.9$ GeV/u ion kinetic energy).

Asymmetric beam energies should be considered also.

Beam luminosities: in the pp mode: $L_{\text{average}} \geq 1 \cdot 10^{32} \text{ cm}^{-2}\text{s}^{-1}$ (at $\sqrt{s_{pp}} = 27$ GeV),
in the dd mode: $L_{\text{average}} \geq 1 \cdot 10^{30} \text{ cm}^{-2}\text{s}^{-1}$ (at $\sqrt{s_{NN}} = 14$ GeV).

Infrastructure. The infrastructure of the Nuclotron-NICA complex should include:

- a source(s) of polarized (non-polarized) protons and deuterons,
- a system of polarization control and absolute measurements (3-5%),
- a system of luminosity control and absolute measurements,
- a system(s) of data distribution on polarization and luminosity to the experiments.

The infrastructure tasks should be subjects of the separate project(s).

Beams intersection area. The area of $\pm 3\text{m}$ along and across of the beams second intersection point, where the detector for the spin physics experiment will be situated, must be free of any collider elements and equipment. The **beam pipe diameter** in this region should be minimal, **10 cm or less**, to guaranty the angular detector acceptance close to 4π . The **walls of the beam pipe** in the region $\pm 1\text{m}$ of the beams intersections should have a **minimal thickness** and made of the **low-Z material (Be?)**.

4. Polarized beams at NICA. (TO BE UPDATED)

The NICA complex at JINR has been approved in 2008 assuming two phases of construction.

The first phase realizing now includes construction of facilities for heavy ion physics program .

The second phase should include facilities for the program of spin physics studies with polarized protons and deuterons.

BMN

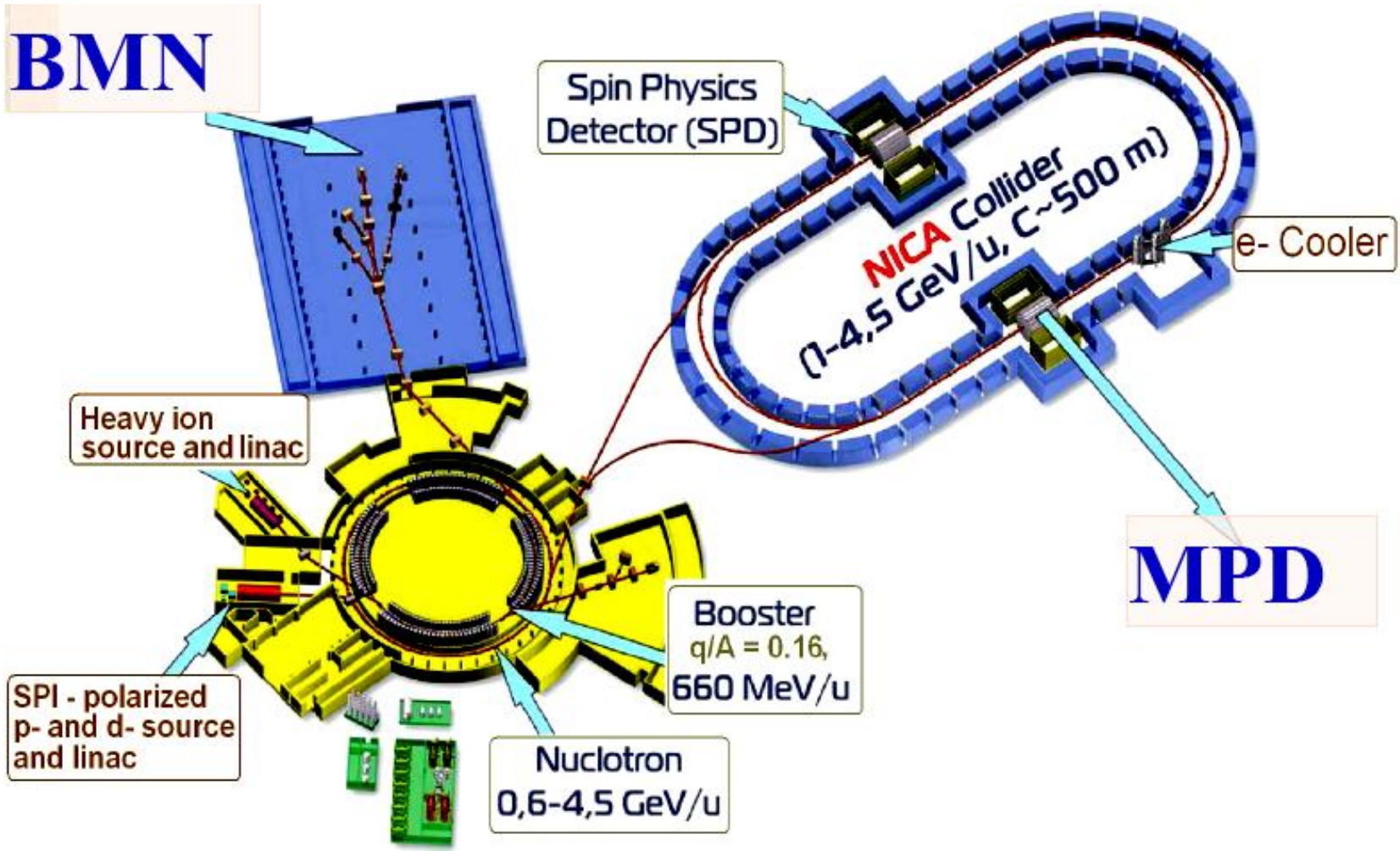

new heavy ion injector

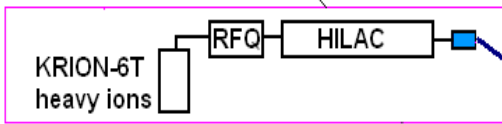

injection to the booster

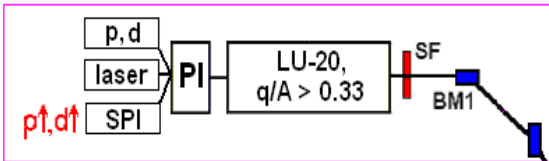

modernized injection chain

transfer from booster

nuclotron fixed target area

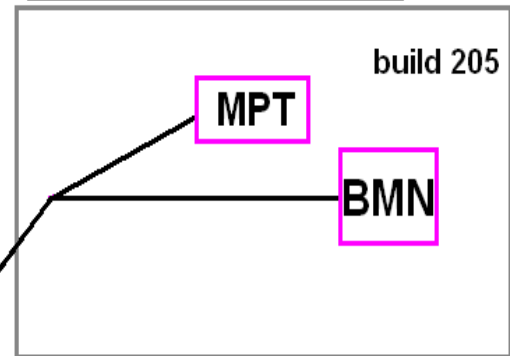

building 1

booster (211 m)

Nuclotron (250m)

extraction from booster

NICA
collider/storage rings
(500m)

SPD

MPD

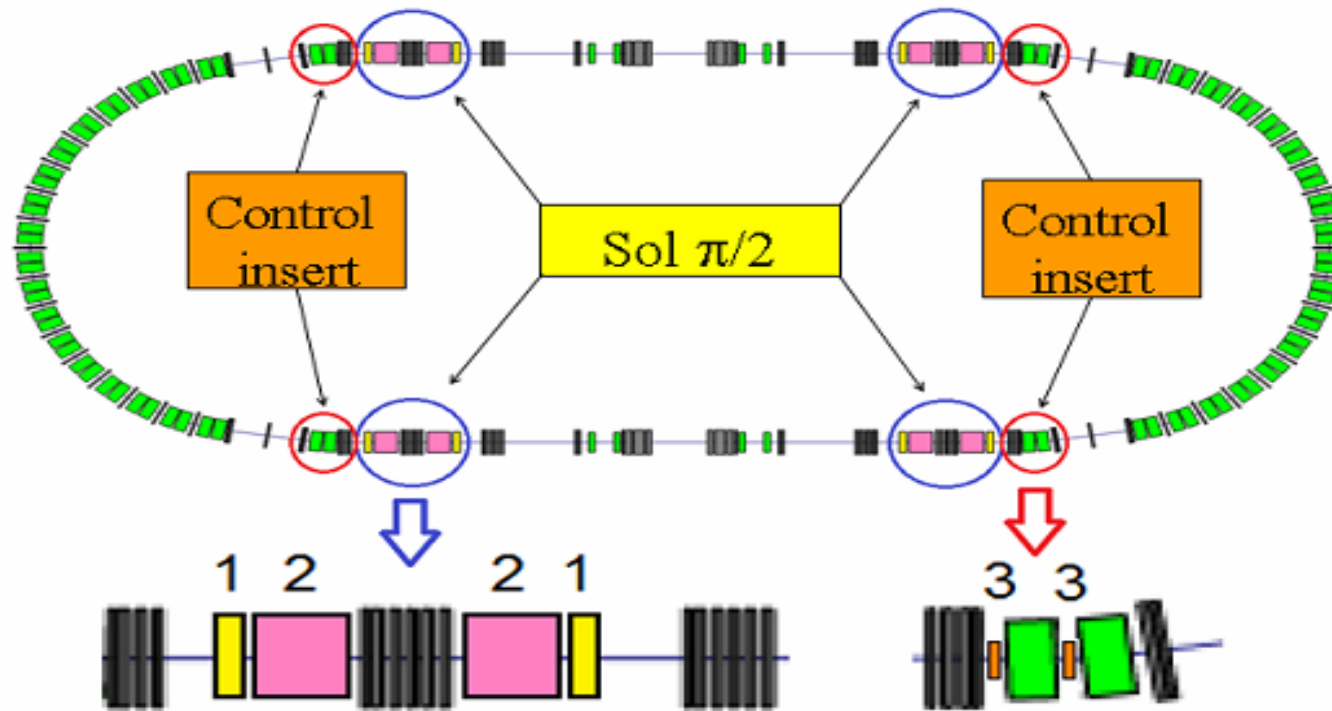

| | Type of solenoid | B_{\max} | L, m | BL, T·m |
|---|------------------|------------|------|------------|
| 1 | Pulse | ± 4 | 1.25 | -5÷5 |
| 2 | Stationary | 9 | 4 | 0÷36 |
| 3 | Weak pulse | ± 0.5 | 0.5 | -0.25÷0.25 |

Feasible schemes of manipulations with polarized protons and deuterons are suggested. The final scheme will be approved at the later stages of the project.

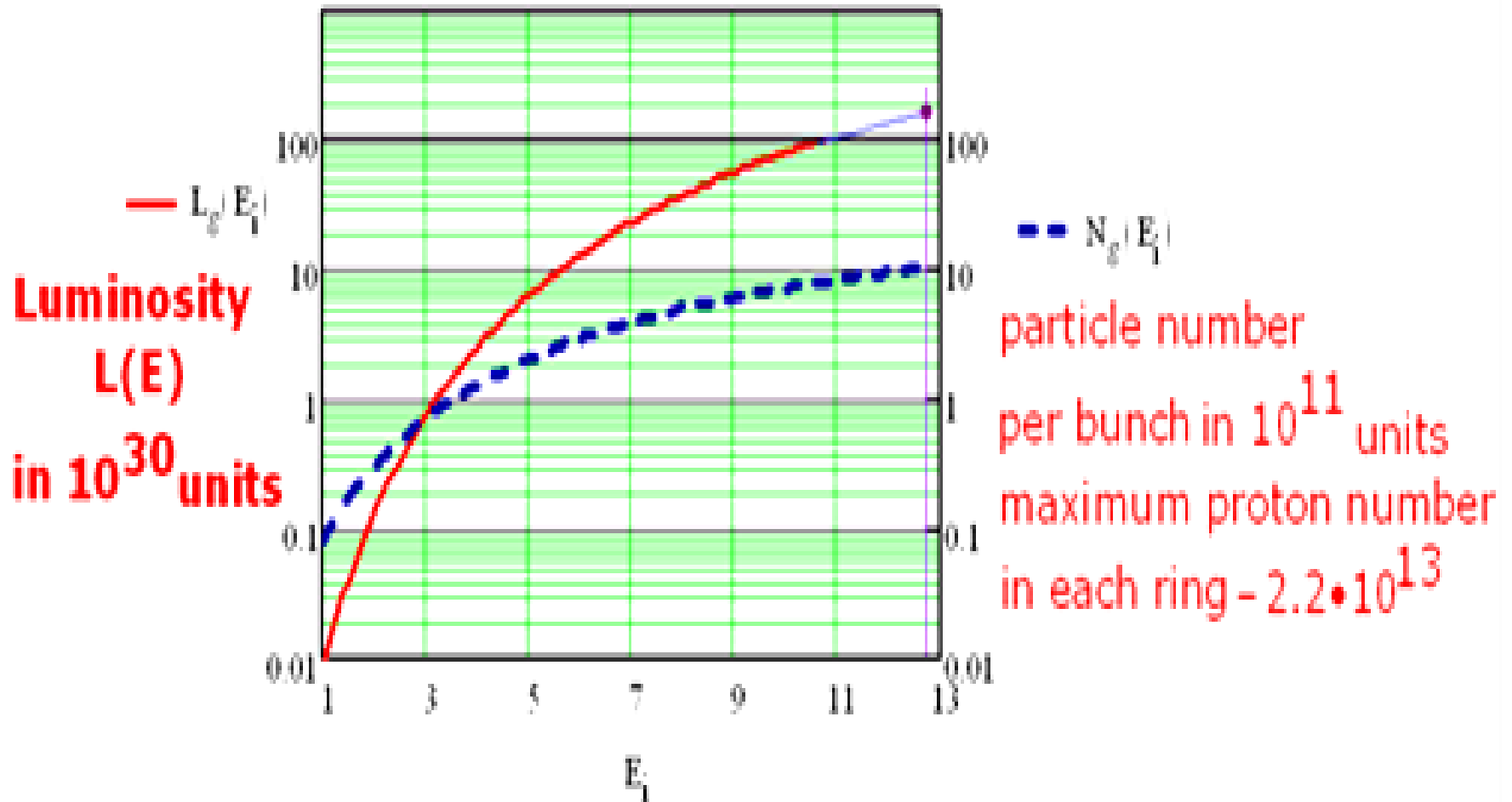

5. Requirements to the spin physics detector (SPD). (AN, IS)

- 5.1. Event topologies.
- 5.2. Possible layout of SPD.
- 5.3. Trigger system.
- 5.4. Local polarimeters and luminosity monitors.
- 5.5. Engineering infrastructure.
- 5.6. DAQ.
- 5.7. SPD reconstruction software.
- 5.8. Monte Carlo simulations.
- 5.9. Slow control.
- 5.10. Data accumulation, storing and distribution.

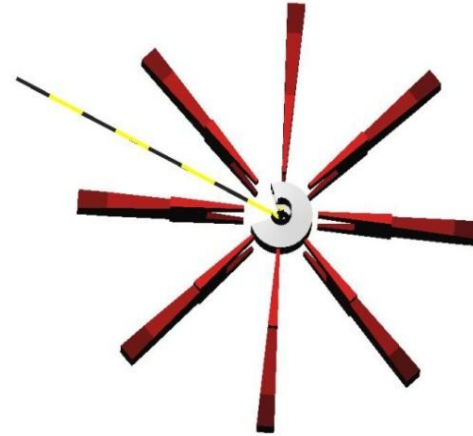
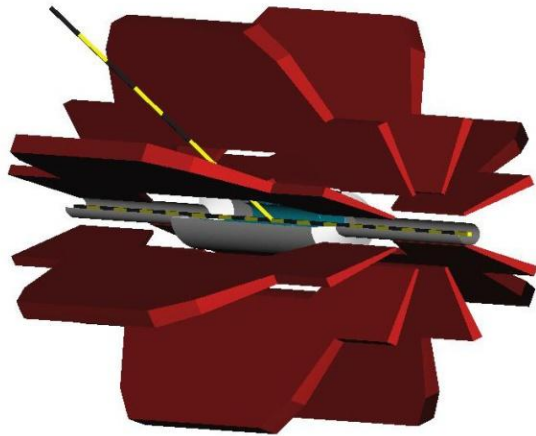

RANGE SYSTEM: HADRON
& MUON DETECTORS

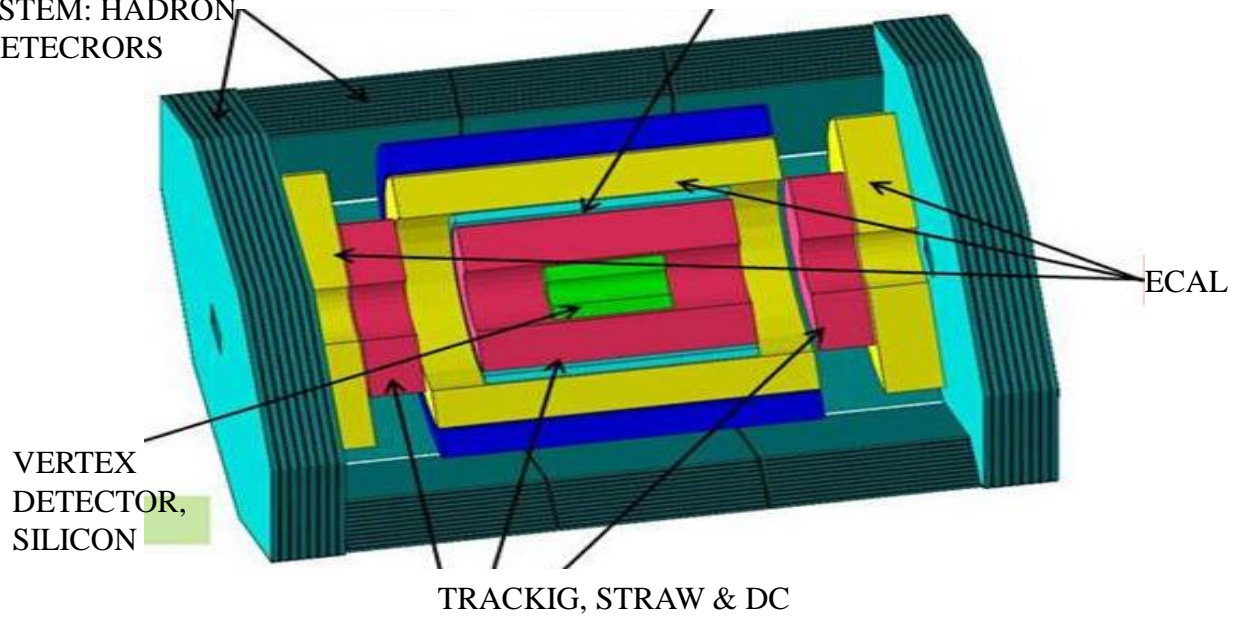

The “almost 4π geometry” requested by DY and direct photons can be realized in the solenoid version of SPD if it has overall length and diameter of about 6 m.

SPD experimental area

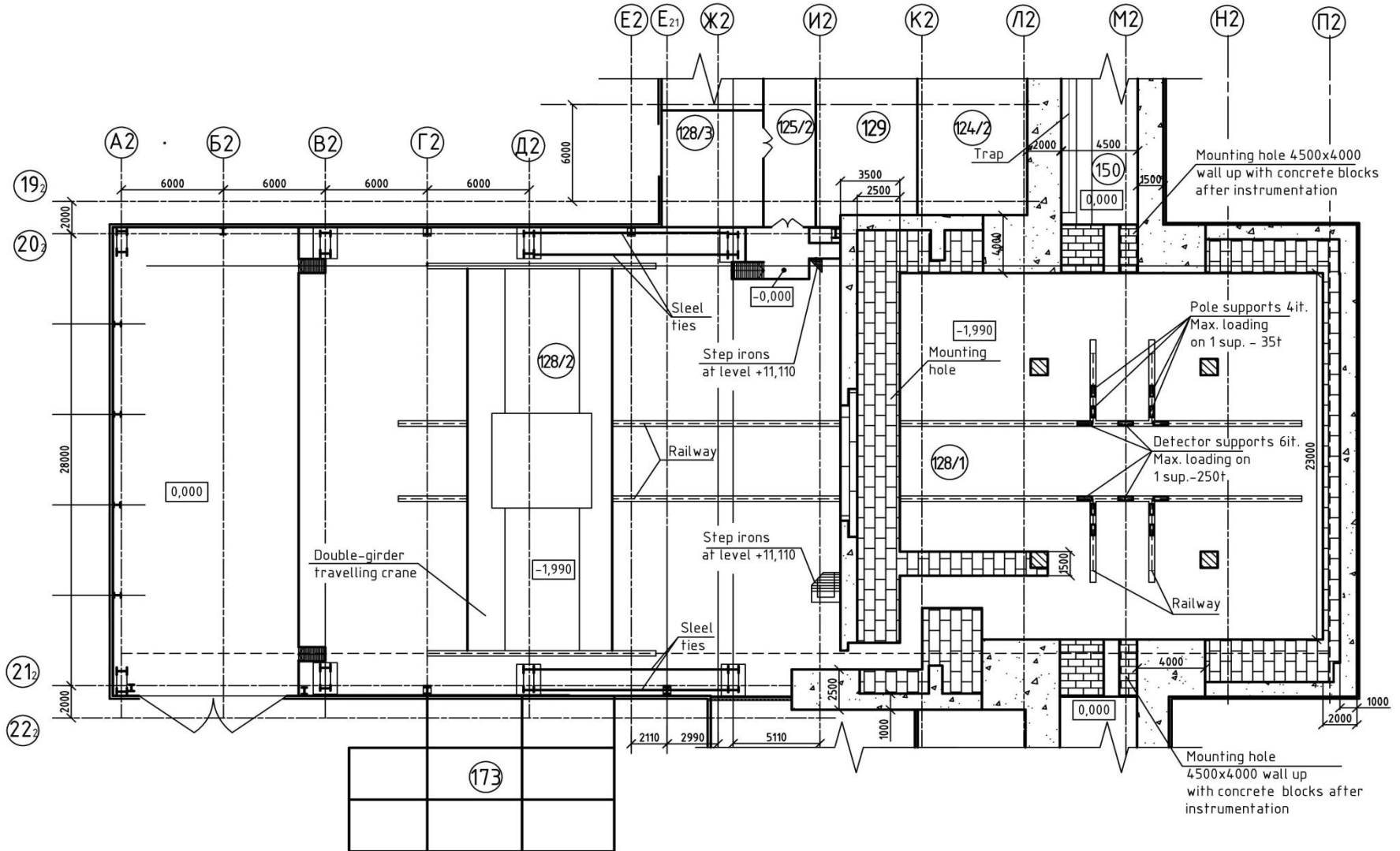

6. Proposed measurements with SPD.

6.1. Estimations of DY and J/Ψ production rates. (AN, OSh)

6.2. Estimations of direct photon production rates. (AG)

6.3. Rates in high- p_T reactions. (SSh)

6.4. Rates in elastic pp and dd scattering.

6.5. Feasibility of the spin-dependent reaction studies in heavy ion collisions.

We propose to perform measurements of asymmetries of the DY pairs production in collisions of polarized protons and deuterons (Eqs.2.1.0) which provide an access to all collinear and TMD PDFs of quarks and anti-quarks in nucleons.

The measurements of asymmetries in production of J/Ψ and direct photons will be performed simultaneously with DY using dedicated triggers.

The set of these measurements will supply complete information for tests of the quark-parton model of nucleons at the twist-two level with minimal systematic errors.

6.1. Estimations of DY production rates

To estimate the precision of measurements, the set of original software packages for MC simulations, including generators for Sivers, Boer-Mulders and transversity PDFs were developed [2]. With these packages we have generated a sample of 100K D-Y events (~ 1 year of data taking) for comparison with expected asymmetries.

Sivers

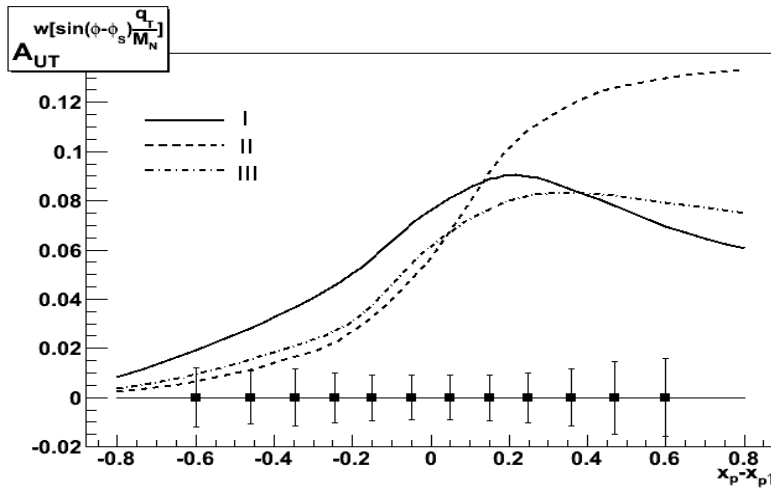

Boer-Mulders

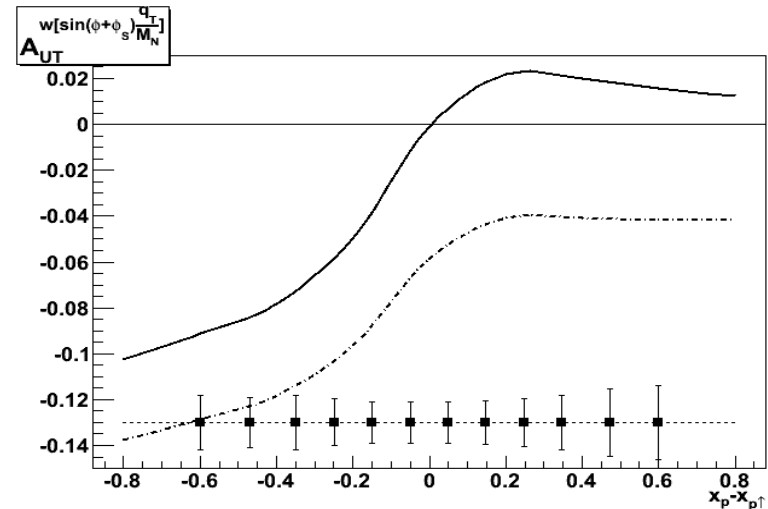

6.2. Estimations of direct photon production rates.

A_N and A_{LL} could be measured at SPD with statistical accuracy $\sim 0.11\%$ and $\sim 0.18\%$, respectively, in each of 18 x_F bins ($-0.9 < x_F < +0.9$).

| $\sqrt{s}=24 \text{ GeV}$ $L = 1.0 \times 10^{32}, \text{ cm}^{-1}\text{s}^{-1}$ | $\sigma_{tot},$ nbarn | $\sigma_{P_T > 4 \text{ GeV}/c},$ nbarn | Events/year, 10^6 | Events/year, $10^6 (P_T > 4 \text{ GeV}/c)$ |
|-------------------------------------------------------------------------------------|--------------------------|--------------------------------------------|------------------------|------------------------------------------------|
| All processes | 1290 | 42 | 3260 | 105 |
| $qg \rightarrow q\gamma$ | 1080 | 33 | 2730 | 84 |
| $q\bar{q} \rightarrow g\gamma$ | 210 | 9 | 530 | 21 |
| $\sqrt{s}=26 \text{ GeV}$ $L = 1.2 \times 10^{32}, \text{ cm}^{-1}\text{s}^{-1}$ | $\sigma_{tot},$ nbarn | $\sigma_{P_T > 4 \text{ GeV}/c},$ nbarn | Events/year, 10^6 | Events/year, $10^6 (P_T > 4 \text{ GeV}/c)$ |
| All processes | 1440 | 48 | 4340 | 144 |
| $qg \rightarrow q\gamma$ | 1220 | 38 | 3680 | 116 |
| $q\bar{q} \rightarrow g\gamma$ | 240 | 10 | 660 | 28 |

7. Time lines of the Project

The participants of the LoI are planning to submit the document for discussions at the JINR and outside during the year 2014.

If it will be approved at JINR by the end of 2014, the corresponding Proposal could be prepared by the end of 2015.

CONCLUSIONS

1. The text of LoI is almost complete for presentations.
2. It will be updated and finalized after the Prague workshop and presentations will start accordingly.
3. Presentation of LoI at PAC on particle physics is planned for 24-25 June 2014.
4. The list of participants is open for interested people .

Back up slides

Twist-2 PDFs of nucleons :

- f_1 - *density* of partons in non-polarized (U) nucleon, (x, Q^2) ;
- g_1 - *helicity*, longitudinal polarization of quarks in longitudinally polarized (L) nucleon;
- h_1 - *transversity*, transverse polarization of quarks in transversely polarized (T) nucleon ;
- f_{1T}^\perp - *Sivers*, correlation between the transverse polarization of nucleon (transverse spin) and the transverse momentum of non-polarized quarks ;
- g_{1T}^\perp - *worm-gear-T*, correlation between the transverse spin and the longitudinal quark polarization ;
- h_1^\perp - *Boer-Mulders*, distribution of the quark transverse momentum in the non-polarized nucleon ;
- h_{1L}^\perp - *worm-gear-L*, correlation between the longitudinal polarization of the nucleon (longitudinal spin) and the transverse momentum of quarks ;
- h_{1T}^\perp - *pretzelosity*, distribution of the transverse momentum of quarks in the transversely polarized nucleon ;

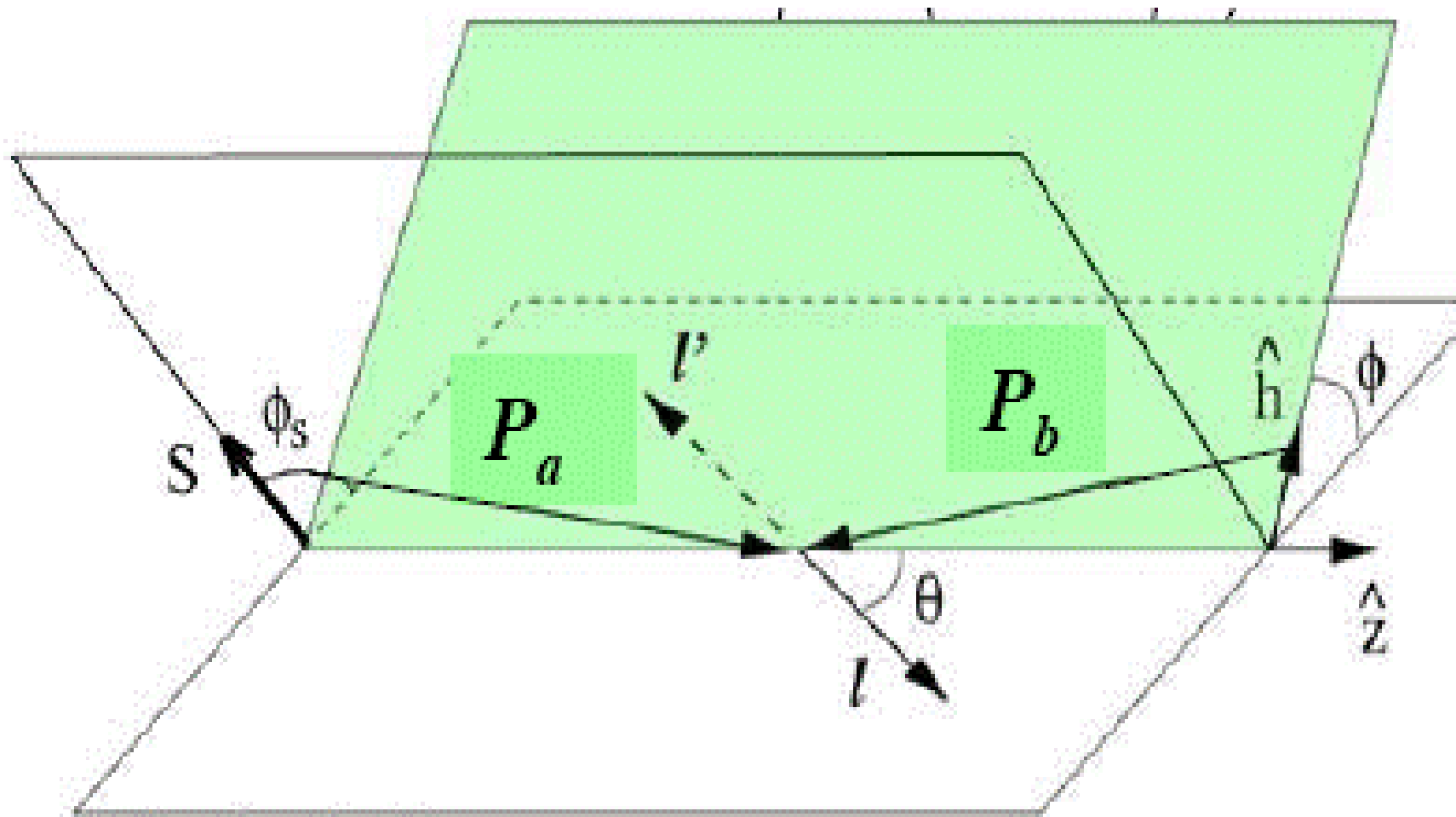

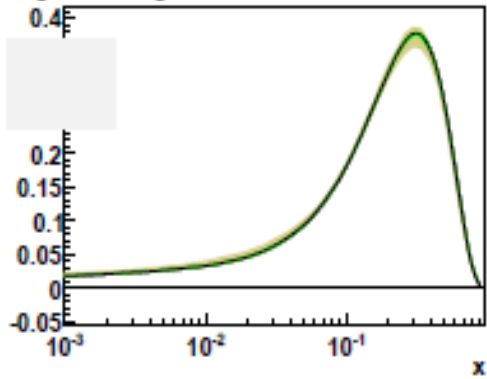
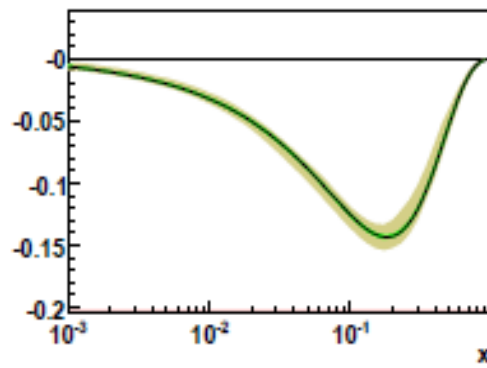
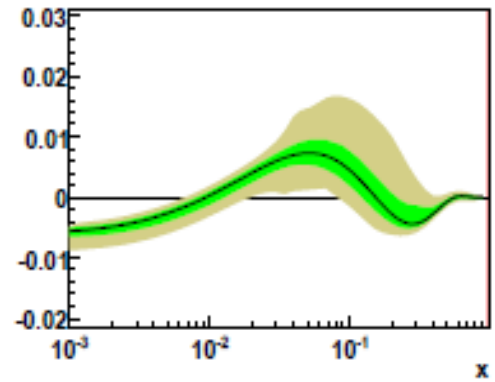
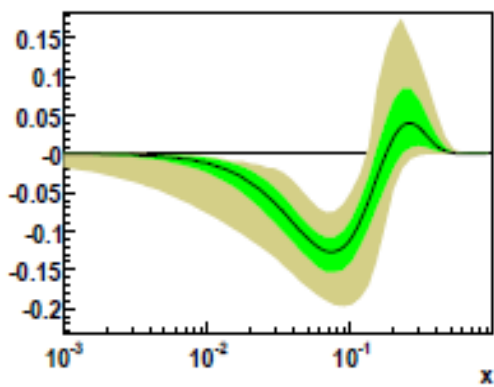
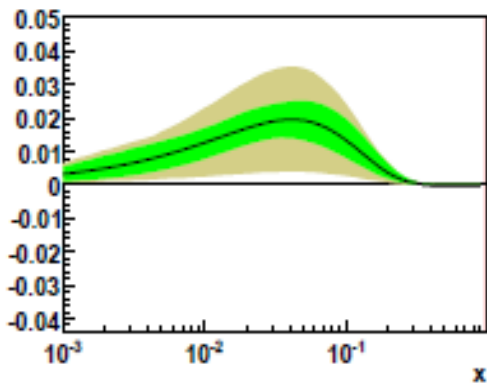
$x[\Delta u + \Delta \bar{u}]$  $x[\Delta d + \Delta \bar{d}]$  $x\Delta s = x\Delta \bar{s}$  $x\Delta G$  $x\Delta \bar{u}$  $x\Delta \bar{d}$ 